

# **SPORTS ART 5009U EDDY CURRENT UPRIGHT BIKE**

## **TABLE OF CONTENTS**

A. SAFETY GUIDELINES.....	1
B. INTRODUCTION.....	2
C. ASSEMBLING YOUR BIKE	
List Of Parts.....	3
Step By Step Instructions.....	4
Floor level adjustment .....	7
Seat Height Adjustment.....	8
D. EXERCISING ON YOUR UPRIGHT BIKE	
Understanding the Electronics Package.....	9
Manual.....	9
SET.....	9
Using the INTERVAL Mode.....	10
PROGRAM.....	11
RESET.....	13
What each of these categories means .....	13
E. MAINTAINING YOUR UPRIGHT BIKE	
Cleaning the bike.....	14
F. GUIDELINES FOR EXERCISE	
How long should I exercise?.....	14
How often should I exercise?.....	14
G. TROUBLE SHOOTING.....	15

## **SAFETY GUIDELINES**

Please read and follow the following safety guidelines:

- . Keep this owner's manual for future use and reference.
- . Read this owner's manual and follow the instructions.
- . Assemble and operate the bike on a solid, level surface.
- . Always unplug the bike from the electronic outlet after using or before cleaning.
- . Never allow children on or near the bike.
- . Check the bicycle before every use. Make sure all parts are assembled, and all nuts and bolts are tightened. Do not use the bicycle if the unit is disassembled in any way.
- . Keep your hands away from moving parts.
- . Wear proper workout clothing: Do Not wear loose clothing. Do not wear shoes with leather soles or high heels. Tie all long hair back.
- . Don't rock the unit from side to side, and use care when mounting and dismounting the unit.
- . Don't stand on the unit.
- . Do not use any accessories that aren't specifically recommended by the manufacturer— these might cause injuries or cause the unit to fail.
- . Allow sufficient space on both side of the bike for users to mount and dismount the machine.
- . Remember to allow space to plug in the unit.
- . The power cord can only be replaced by a qualified technician.
- . If any parts fail or are defective, please stop your workout immediately and contact your authorized dealer for repairs.
- . Work within your recommended exercise level—do NOT work to exhaustion.
- . If you feel any pain or abnormal sensations, STOP YOUR WORKOUT and consult your physician immediately.

### **CAUTION:**

Before beginning any exercise program, you should consult with your doctor. It is recommended that you undergo a complete physical examination.

## **INTRODUCTION**

Congratulations on purchasing one of the finest pieces of exercise equipment on the market today, the Sports Art 5009U. Constructed of high quality materials and designed for years of trouble-free usage, the Sports Art 5009U will be an integral part of your fitness regimen.

Before using your 5009U bike, we recommend that you familiarize yourself with this Owner's Manual. Whether you are a first time user of an exercise bicycle or a seasoned "pro," understanding the correct use of the equipment will enhance your ability to achieve your exercise goals safely and successfully.

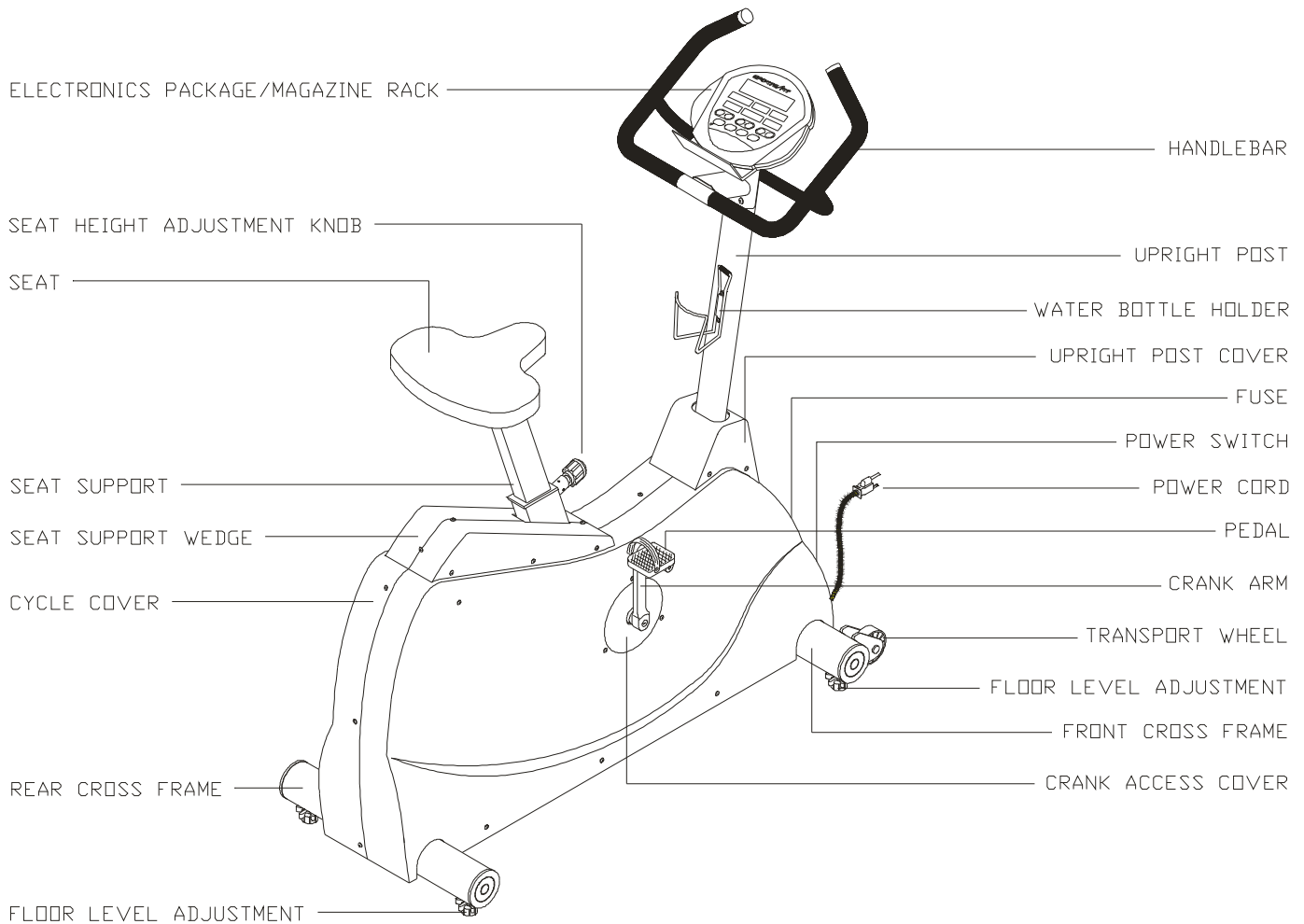

## **ASSEMBLING YOUR BIKE**

### List Of Parts:

- . Six 5/16"x 3/4" bolts – Upright post
- . Four 5/16 wave washers – Upright post
- . Two 5/16" flat washers – Upright post
- . Four Philip screws – Upright post cover
- . One pair of foot pedals
- . One Water bottle
- . Two M5 x L12 bolts – water bottle holder
- . One fuse – 1 AMP
- . One hex Allen wrench
- . One open-ended wrench
- . Two-way screw driver
- . One hex socket

## Step By Step Instructions

Before assembling your bike, make sure that you have all the parts listed on the previous page. The following steps explain how to assemble your 5009U upright bike. Please read every step thoroughly and follow the directions completely to ensure correct assembly.

Important: The packaging for this unit was designed to protect it during shipment. Please store the original packaging in a safe place in case you need to ship the unit in the future.

1. Take out the cycle frame and make sure all packing material are removed from the unit.
2. Place the upright bike on a level, flat surface.
3. Slip the post cover onto the upright post. (see Fig 1)

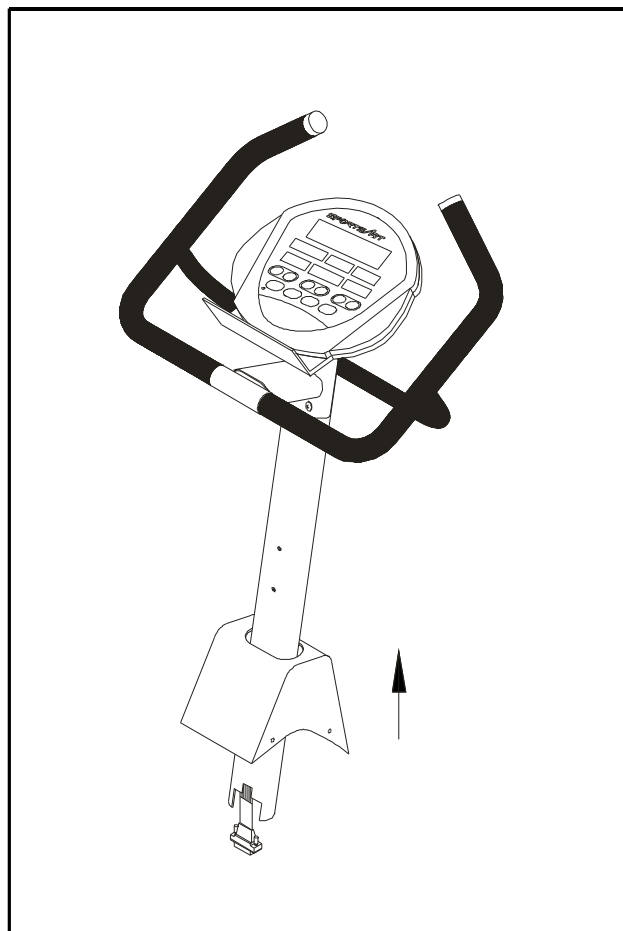

Fig.1

4. Locate the 16 pin cable connector inside the upright post and insert it into the socket of the bicycle frame. Tighten the connector securely by turning both screws pins clockwise (see Fig. 2).

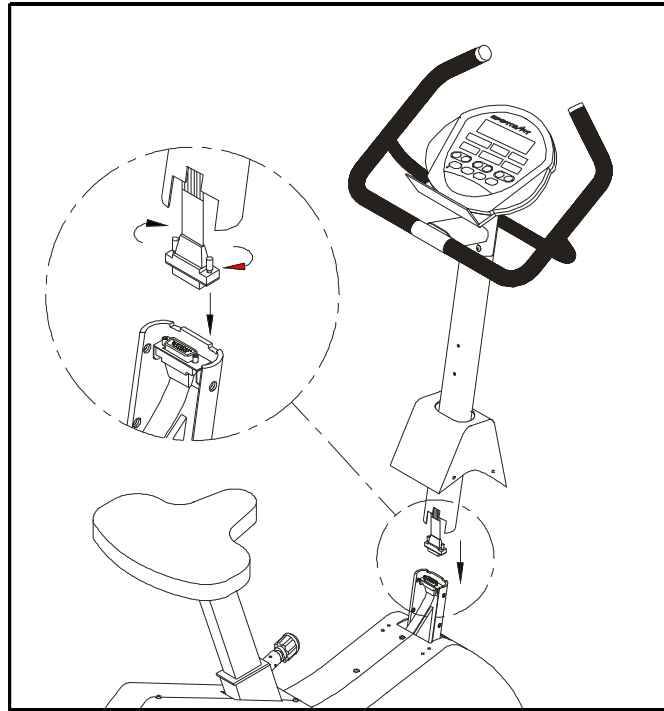

Fig.2

5. Insert the upright post into the cycle frame, securing with six bolts and washers (two bolts and wave washers on each left and right side, and two bolts and flat washers on the front side), as shown in Fig 3.

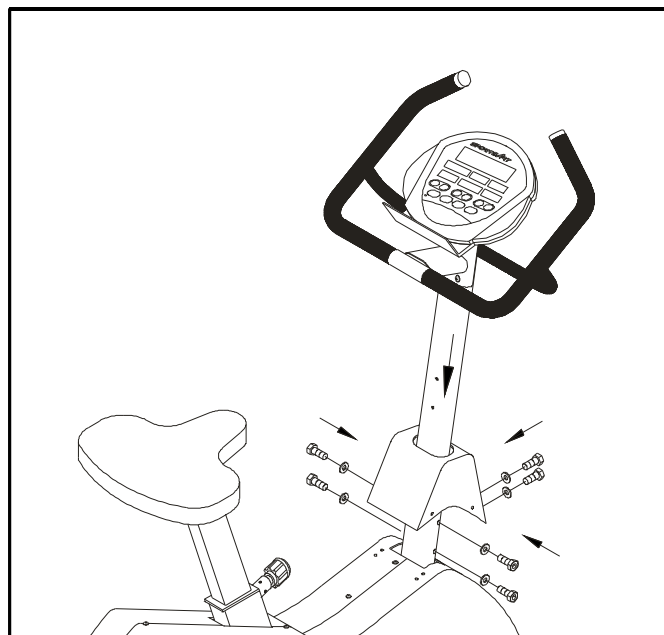

Fig.3

6. Slide the post cover down into place, and secure with four screws. (see Fig 4)

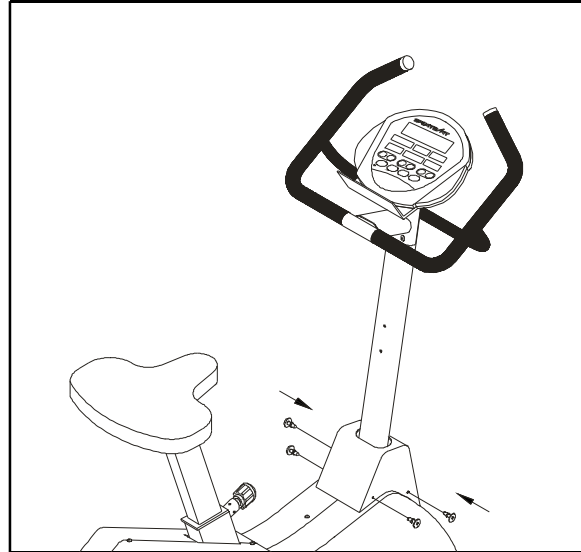

Fig.4

7. Attach the foot pedals to the crank arms of the bike. Be careful to install the pedals on the correct crank arms. Use an open-ended wrench to tighten the pedals securely (see Fig 5)

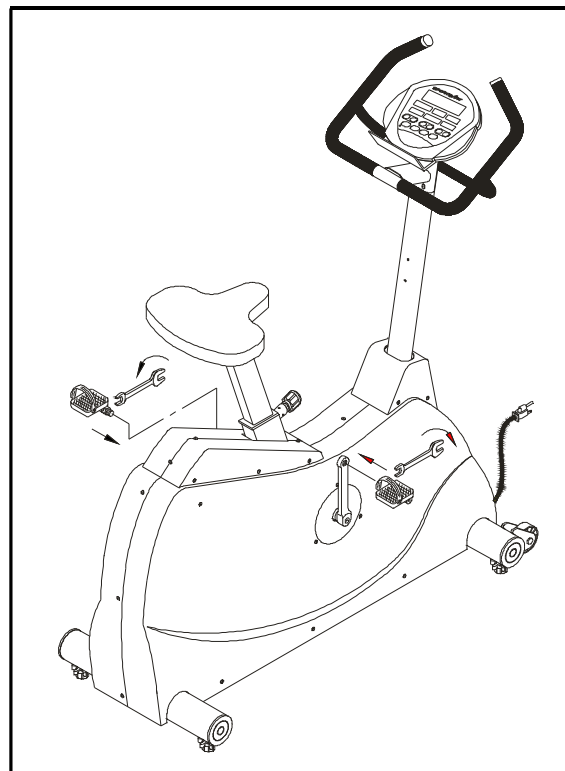

Fig.5

A "R" or "L" on the foot pedal indicates the correct side. Install the pedal marked "R" on the right-hand crank arm (as you stand at the rear of the bike facing front). When you install the pedal marked "L" on the left-hand crank arm, rotate the pedal counterclockwise to tighten since the pedal has left-hand screw threads.

8. Assemble the water bottle holder using two screws provided (see Fig 6).

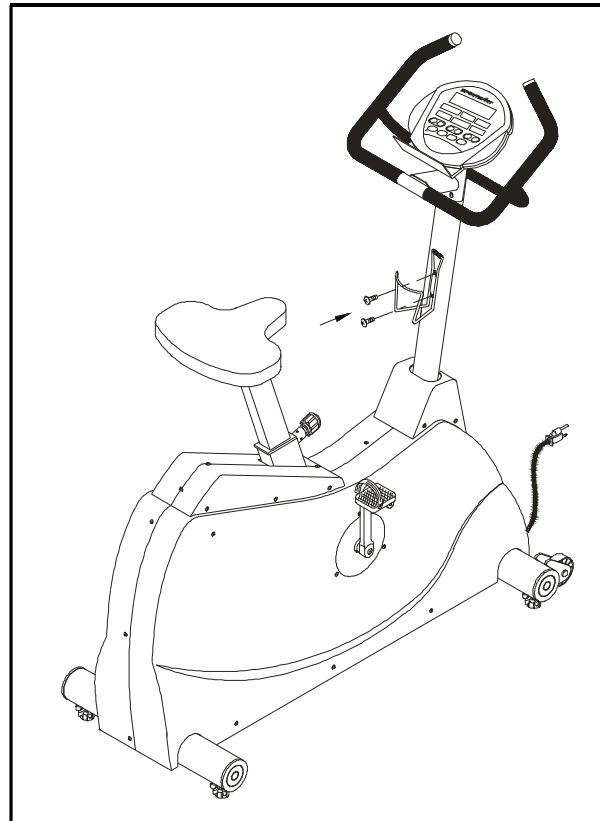

Fig.6

### Floor level adjustment

If the bike is unsteady on your floor, turn the floor level adjustment located either on the rear feet or front cross frame. Raise or lower the floor level adjustment to steady your bike. Tighten the floor level adjustment by turning it counterclockwise. (See Fig 7)

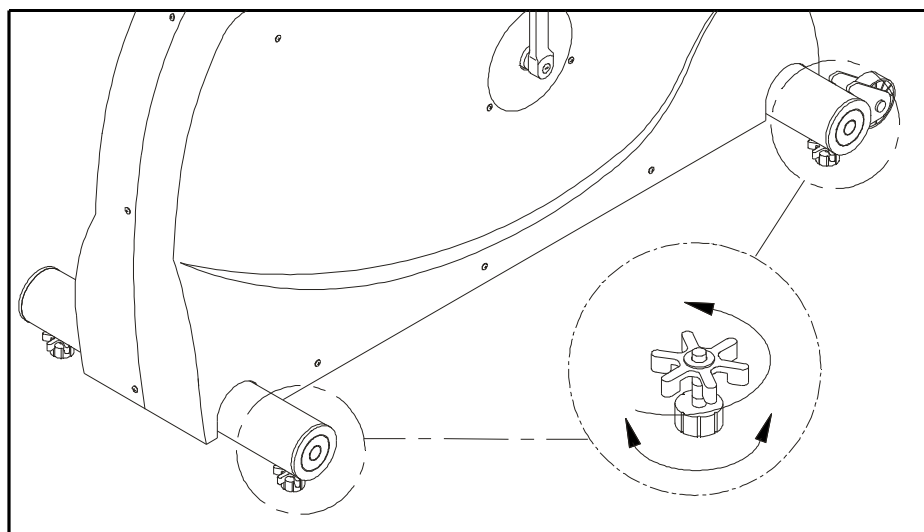

Fig.7

## Seat Height Adjustment

To adjust the seat up or down, turn the height adjustment knob locating on the seat support counterclockwise, then pull out and adjust the seat height to your desired position (see Fig.8). Then, release the knob and turn it clockwise into position to secure the seat. (see Fig 9)

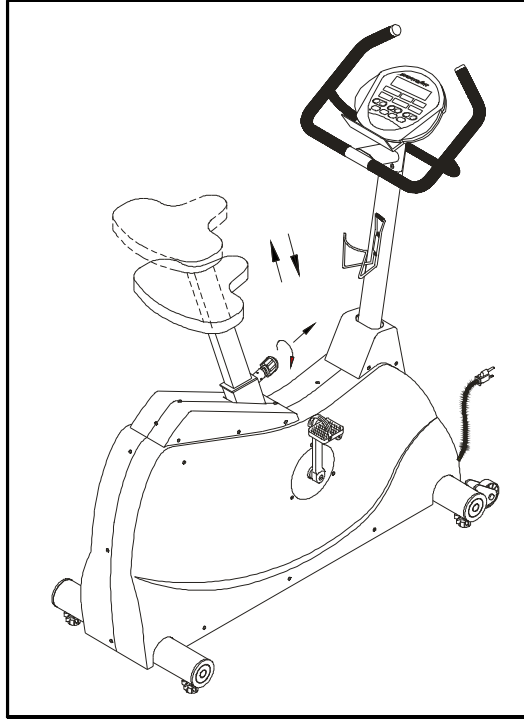

Fig.8

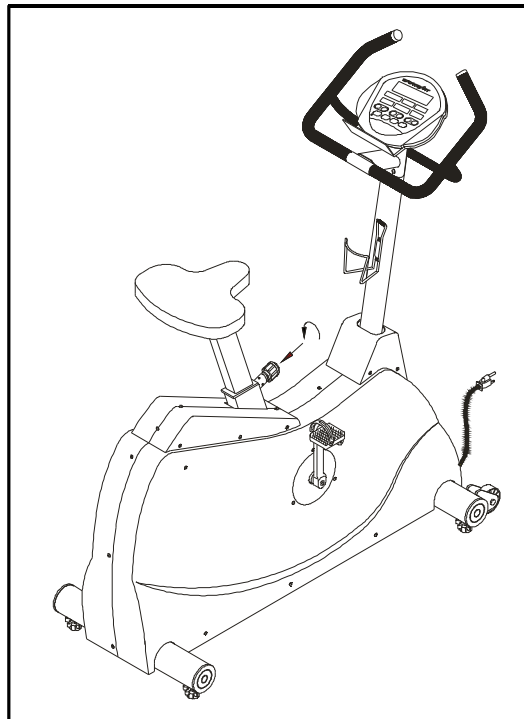

Fig.9

Your 5009U upright bike is assembled and ready to use.

## **EXERCISING ON YOUR UPRIGHT BIKE**

### Understanding the Electronics Package

Plug the POWER CORD into an electrical outlet, then turn on the power switch located on the front of the bike. The main window of electronic package will automatically appear "MAN'L". If this is the Mode you wish to start, you may simply pedal the bike to begin. You may also press other function keys and follow the scrolled messages to start your workout.

If you do not pedal within 3 seconds or you stop in the middle of your workout, you will be prompted to PEDAL TO START WITH LOAD IN LEVEL (WATTS).

### Manual:

1. As soon as you turn on the machine, you will go straight into the MANUAL MODE, "MAN'L" will appear in the central window.
2. You can press LOAD ▲▼ buttons to adjust your desired load.  
  
You can press TIME ▲▼ buttons to set your workout time.  
  
You can press DISTANCE ▲▼ buttons to set the desired distance.
3. After you finish your setting, if you do not pedal within 3 seconds or you stop in the middle of your workout, the central window will display "PEDAL TO START WITH LOAD IN LEVEL (WATTS)" to prompt you to pedal the bike. All input information (LOAD, TIME or DISTANCE etc.) will be retained.
4. When your desired time or distance is reached, a beep tone will sound for 10 seconds to alert the user.

### SET:

Press the MANUAL/SET key, and "MAN'L" will show in the display. Press the key once again, and "SET" will appear in the display. Then press ENTER.

1. You can choose between MILE/KILO, MALE/FEMALE and WEIGHT while in the SET MODE.
2. The read out will display "PRESS ▲▼ TO SELECT MILE/KILO". Press ▲▼ keys to select either MILE or KILO, then press ENTER to save your selection.

(Note: choosing MILE will automatically select pounds in the weight calculation, and choosing KILO will automatically select kilograms in the weight calculation.)

3. You will be prompted to choose between "MALE / FEMALE". Use the ▲▼ to select your choice, the window display will be "♂ -M" or "♀ -F", press ENTER to record that choice.

4. Next, "ENTER WEIGHT" will scroll across the screen. Then the last weight setting will show on the display. Use the ▲▼ to change your desired weight.

Once you have set your desired weight, press "ENTER" to record them. This will allow the unit to calculate your calorie expenditure.

#### Using the INTERVAL Mode:

##### A. Interval 1:

1. Press the INTERVAL key and you will be in "INTV. 1" press ENTER, and the window will display the message: "INPUT REST LOAD & TIME, THEN PRESS ENTER". Follow the below steps:
  - a. REST will appear in the central display.
  - b. Adjust the desired load using the ▲▼buttons.
  - c. Select the desired REST TIME (in seconds) using the ▲▼buttons,
  - d. Then press ENTER to confirm your input data.
2. Once the REST load and time has been set, the display will read "INPUT WORK LOAD & TIME, THEN PRESS ENTER", and then "WORK" will appear in the main window.

Adjust your desired LOAD and TIME by using the ▲▼buttons, then press ENTER to complete the setting.

3. You will be prompted to "PEDAL TO START", and the bike will automatically adjust the load according to your entered preferences.
4. When pedaling, the window will display the course profile and countdown to zero for each segment.
5. When the REST interval is over, the display will show "GOING TO WORK LOAD", and the machine will adjust to the settings you chose for the work interval. When the WORK time is over, the display will show "GOING TO REST LOAD", and return to the settings you chose for the rest interval.
6. You can change the load at any time during your workout.
7. Please keep in mind that the TIME range is 60 ~ 250 seconds

## B. Interval 2

Interval 2 allows you to design your own personal workout program.

There are EIGHT segments in Interval 2. Press the INTV button until you see INTV. 2 in the window, then press ENTER.

You will be prompted to "INPUT LOAD LEVEL (or WATTS) & TIME OF SEGMENT 1". Then "SEG 1" will appear on the display. Use the ▲▼ keys to select the desired LOAD and TIME, then press ENTER.

After you have set your desired SEG. 1 setting, "SEG. 2" will appear in the window. For Segments 2-8 settings, please refer to the instructions as above. Once all segments are set, your own personal program, under INTV. 2 will be recorded.

If you only want to set four segments, for example, leave the TIME of segment 5 with a value of zero, and the bike will perform only your desired four segments.

When pedaling, the window will display the course profiles and they will flash from SEG 1.

At the end of each segment, the display will read "GOING TO SEGMENT X"  
You can change the tension level during your workout.

If you stop in the middle of your workout, you will be prompted to "PEDAL TO START". All input information (TIME, DIST., CAL., etc.) will be retained.

### PROGRAM:

The 5009U features a total of six (6) professionally designed workout programs. The programs control the load of your workout.

1. Press the PROGRAM buttons to scroll between the 6 Programs. When you have chosen the program you want, press "ENTER".
2. You will be prompted to "PRESS ▲▼ TO SET TIME/DIST". You can only set TIME or DISTANCE (but not both). Use ▲▼ buttons to set your desired TIME or DISTANCE, then press ENTER. If you don't press ENTER, the display will prompt you to "PRESS ENTER".
3. The program profile will be displayed in the main window, and will begin when you start the unit by pedaling. If you do not begin pedaling immediately, you will be prompted to "PEDAL TO START".
4. During these programs, the unit will automatically switch between loads, giving you the feeling of riding on hills or level ground.

- 5. When your desired DIST. or TIME is reached, a beep will sound for 10 seconds, and after that the machine will begin to count up.
- 6. Even though the programs feature preprogrammed loads, you can change the load anytime during your workout.
- 7. If you stop in the middle of your workout, you will be prompted to "PEDAL TO START". All input data will be retained.

**The course profiles for each PROGRAM are as follows:**

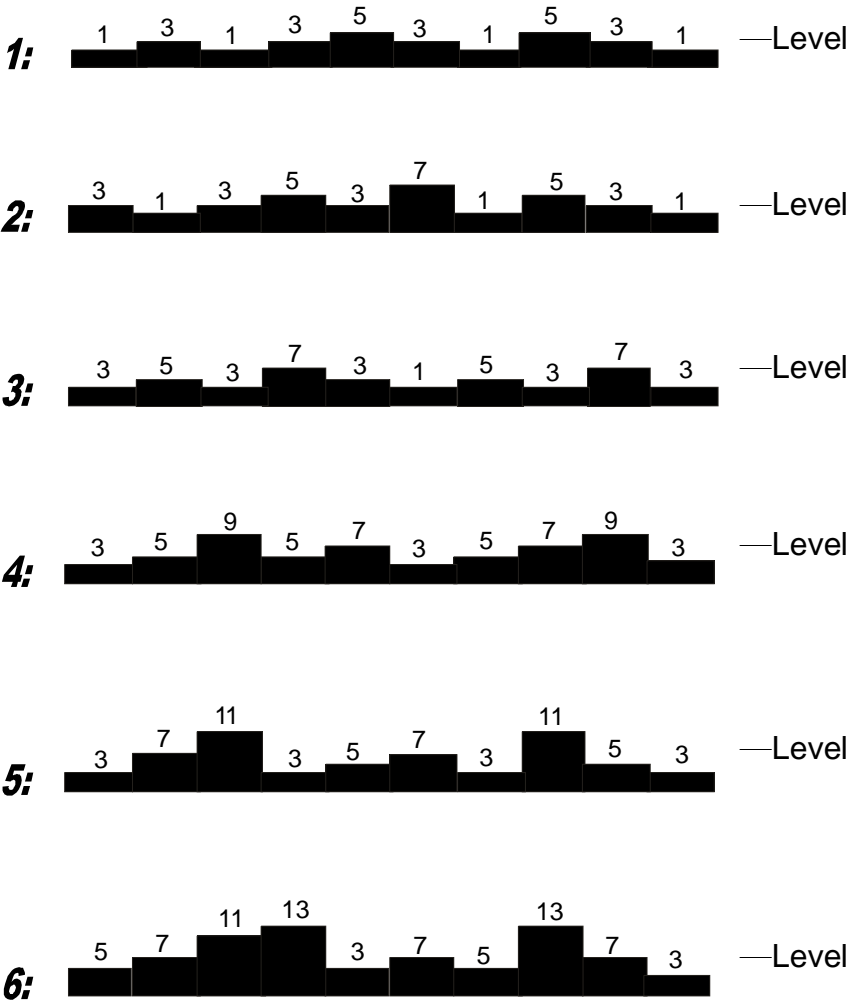

## RESET

To change any of your data in MAN'L, SET, INV and PROGRAM, simply hold the ENTER button to RESET, the existing date will be cleared, and the display will return to the original operation mode for your resetting.

What each of these categories means:

**LOAD (LEVEL):** There are 14 levels, with LEVEL 1 being the lightest, and LEVEL 14 being the heaviest. Use the ▲▼ buttons to choose the desired level. Pressing the key once changes the load one level. Holding the key down will change the load one level every 0.5 second.

**TIME:** Use the ▲▼ keys to set the desired time. Pressing the key once changes 1 minute. Holding the key down will change the time 5 minutes every 0.5 second. The electronics package will beep for 10 seconds when your desired time is reached, then will start to count up if your workout continues.

**DIST:** Use the ▲▼ keys to set the desired distance. Each press of the key changes the distance by 0.05 miles (0.1 km). If you hold down the keys, the numbers will increase or decrease by 0.5 miles or 1 km every 0.5 seconds. The electronics package will beep for 10 seconds when your desired distance is reached, then will start to count up if your workout continues.

**RPM:** A sensor counts the number of revolutions the flywheel makes per minute, and this is displayed on the screen.

**PULSE:** (if your bike is equipped with heart rate function)

This readout gives you the heart rate per minute.

**CAL:** This readout gives you the amount of calories burned, based on the weight entered and speed/distance cycled during your workout.

## **MAINTAINING YOUR UPRIGHT BIKE**

This bike requires little maintenance. The bike's low friction operation is dependent on keeping the unit as clean as possible.

### Cleaning the bike

CAUTION: Turn off unit and disconnect AC cord before cleaning.

Regular cleaning is recommended to keep your bike at peak performance. Before your workout, use a dry cloth to clean the surface of the electronics package.

Note: NEVER POUR LIQUIDS ON THE ELECTRONICS PACKAGE.

To clean the plastic parts, use a mild detergent and make sure the unit is completely dry before operating.

It is recommended that you keep all liquids away from the unit during operation. Spillage of liquids onto or into the machine will void the warranty.

## **GUIDELINES FOR EXERCISE**

### How long should I exercise?

The duration of your exercise session is dependent on your fitness level. In general, it is recommended that you maintain your heart rate in the training zone for at least 10 minutes to realize an aerobic benefit. As your fitness level increases, you will be able to maintain your heart rate in the training zone for longer periods, usually between 20 and 30 minutes.

When starting your workout, use the first several minutes to warm up, then slowly increase your workload to bring your heart rate into your specific training zone. At the end of your workout, gradually decrease your workload, then exercise lightly as a "cool down".

### How often should I exercise?

Aerobic exercises, to achieve the greatest benefits, should be performed 3-5 times a week.

It is important to allow sufficient time, at least 24 hours, for your body to recover after exercise.

## **TROUBLE SHOOTING:**

### **A. NO POWER**

1 If you turn on the power switch and there is no light:

- a. Check if the power cord is plugged securely into the wall socket.
- b. After the above step is performed, if the power switch is still not lit, please replace the fuse.

**CAUTION:** Make sure to unplug the power cord from the wall socket before replacing the fuse.

**To remove:**

Find the 1A fuse holder located on the front of the machine, push on the fuse holder and turn the fuse holder counterclockwise to remove the damaged fuse. (see Fig 10-1 ~ Fig 10-2)

**To install:**

Insert a new fuse into the holder, push the fuse and holder in, then turn the fuse holder clockwise to secure. (see Fig 10-3 ~ Fig 10-4)

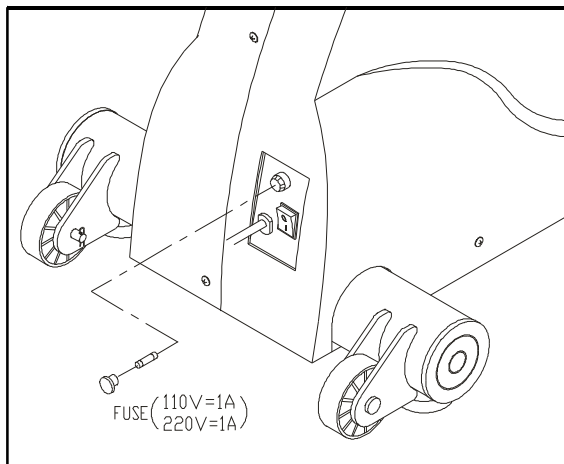

Fig.10-1

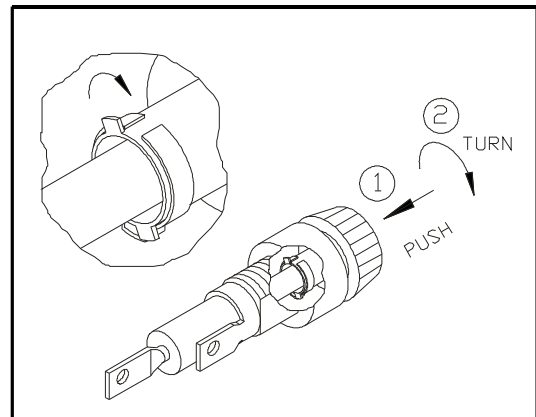

Fig.10-2

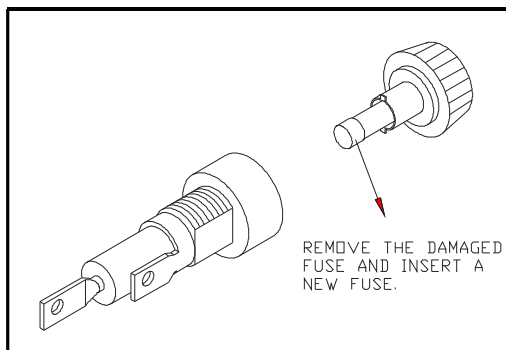

Fig.10-3

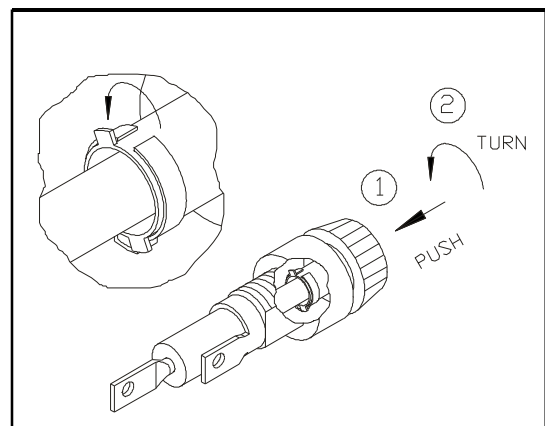

Fig.10-4

- c. Plug the power cord into the wall socket and turn on the machine again. If the power switch is still not lit, please contact your authorized dealer for more information.
2. If you turn on the power switch and the switch is lit, but there is no display, please contact your authorized dealer for more information.

#### B. Others

If your bike has other problems, such as no tension, no "RPM", or other readings while pedaling, please contact your authorized Sports Art dealer for more details.

Wiring Schematic:

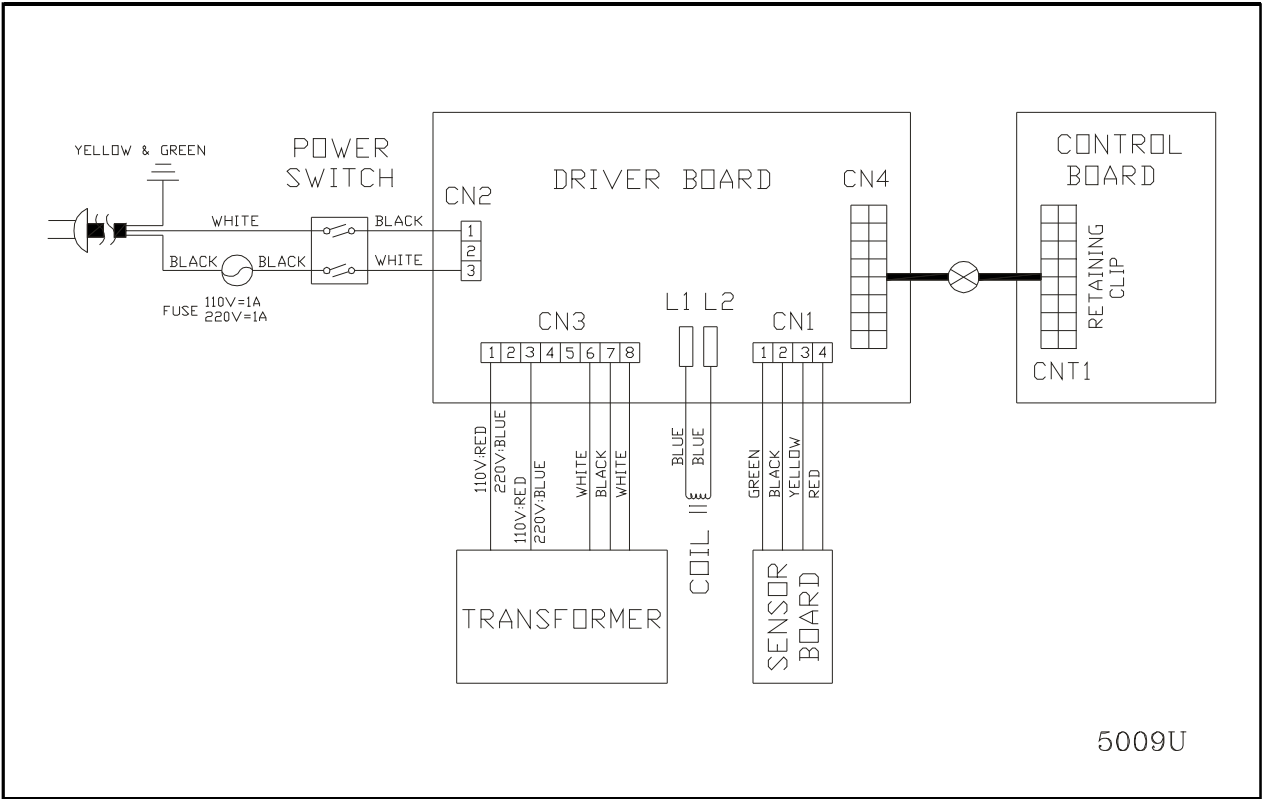

**Your Authorized Distributor**